

CDP 35

FUNCTION

The CDP 35 works in accordance with the condensation principle. A fan draws the humid air into the dehumidifier and through an evaporator coil. When passing through the evaporator the air is cooled down to below its dew point temperature, and its content of water vapour is condensed into water, which falls into the drip tray and then is led from the drip tray to a drain. The cold, dry air is then passed over the condenser coil where it is re-heated, before leaving the unit at a temperature, which is approx. 5°C higher than at the inlet.

CONSTRUCTION

- The CDP 35 is built into a hot-galvanized sheet metal cabinet
- All external and internal parts of the cabinet are enamel powder painted
- The CDP 35 is fixed to the wall by means of a wall mounting strip supplied with the unit
- The condensate outlet is located at the bottom of the CDP 35. The outlet stub can be connected to a 1/2" water hose
- Air intake through a filter that is placed behind the front panel
- Rotary compressor
- Radial fan
- The CDP 35 can be floor mounted by means of a floor mounting kit (optional extra)

ELECTRONIC CONTROL

The CDP 35 has a built-in hygrostat and is fully automatic with electronic control. The hygrostat is factory set to approx. 60% RH. An easy to read display panel indicates the current status of operation.

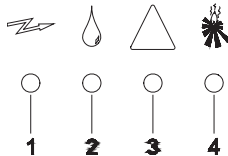

1. Power on
2. Dehumidification – the compressor is on
3. Cooling circuit failure – the dehumidifier is switched off
4. After heating coil is activated.

Passive, demand-controlled defrosting is incorporated in the electronic control. A sensor on the evaporator coil ensures that the evaporator is only defrosted when required. The compressor is switched off during defrosting and the fan blows room air through the evaporator, thereby melting the ice on the evaporator.

If the relative humidity has to be adjusted frequently, a remote room hygrostat can be connected to the CDP 35.

TECHNICAL DATA

		CDP 35
Operating range – humidity	%RH	40 – 100
Operating range – temperature	°C	10 – 36
Air volume	m ³ /h	250
Power supply	V/Hz	1x230/50
Max. ampere consumption	A	2,8
Max. power consumption	kW	0,72
Refrigerant		R407C
Quantity of refrigerant	kg	0,600
Sound level (at 1 metre)	dB(A)	47
Weight	kg	60
Colour	RAL	7044 / 9016
Protection class		IPX4

CAPACITY CURVES

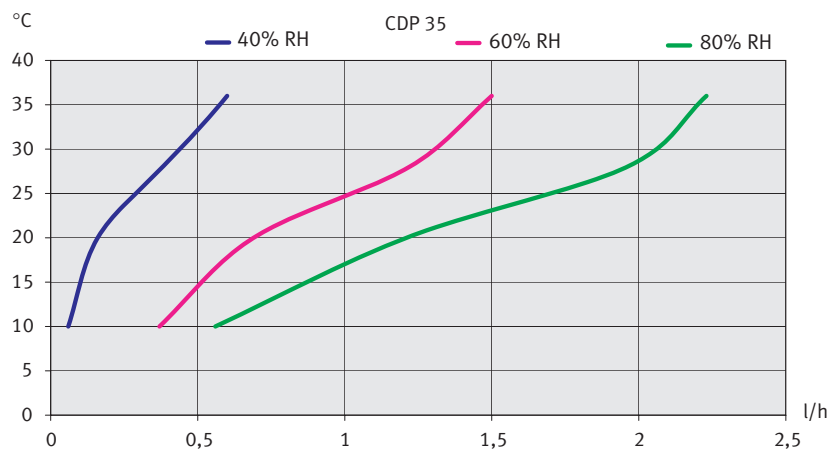

DIMENSIONS

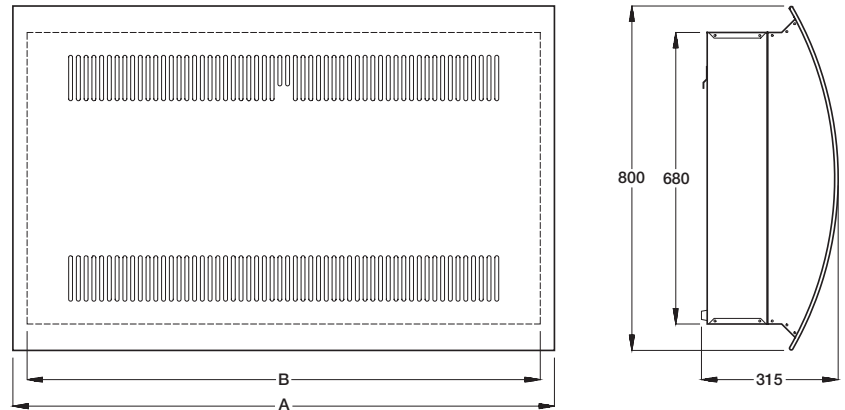

	A	B
CDP 35	950	890

Drain outlet position

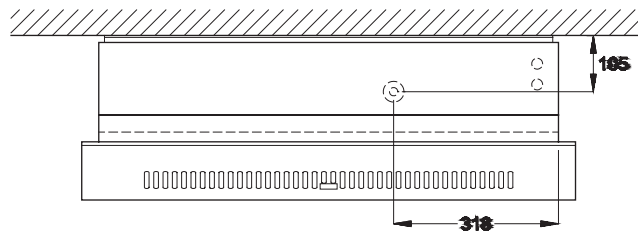

Recommended placing of the CDP 35

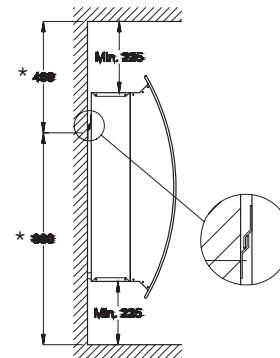

Floor mounting kit

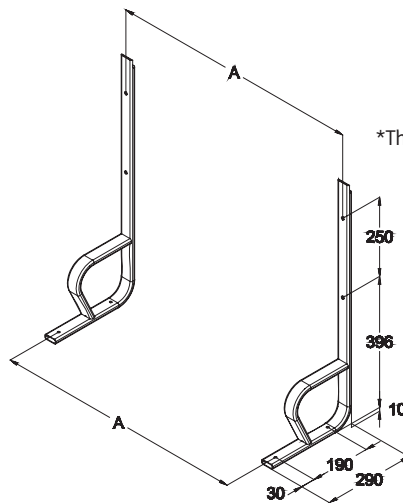

	A
CDP 35	645

*The dimensions indicate the placing of the wall mounting strip

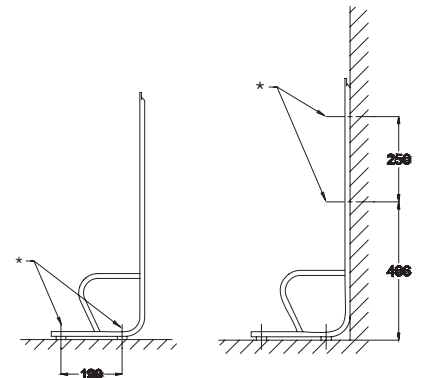

* To be fixed to the floor or the wall

ACCESSORIES

- Room hygrosat
- Floor mounting kit
- Ext. failure monitoring
- After heating coil

All dimensions are in mm

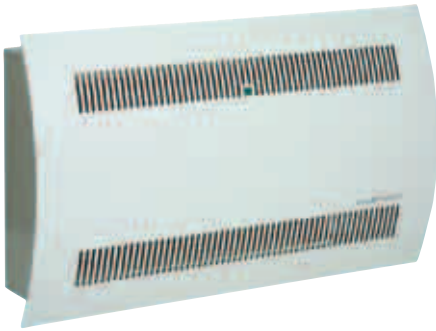

CDP 45

FUNCTION

The CDP 45 works in accordance with the condensation principle. Two fans draw the humid air into the dehumidifier and through an evaporator coil. When passing through the evaporator the air is cooled down to below its dew point temperature, and its content of water vapour is condensed into water, which falls into the drip tray and then is led from the drip tray to a drain. The cold, dry air is then passed over the condenser coil where it is re-heated, before leaving the unit at a temperature, which is approx. 5°C higher than at the inlet.

CONSTRUCTION

- The CDP 45 is built into a hot-galvanized sheet metal cabinet
- All external and internal parts of the cabinet are enamel powder painted
- The CDP 45 is fixed to the wall by means of a wall mounting strip supplied with the unit
- The condensate outlet is located at the bottom of the CDP 45. The outlet stub can be connected to a 1/2" water hose
- Air intake through a filter that is placed behind the front panel
- Rotary compressor
- Radial fans
- The CDP 45 can be floor mounted using a floor mounting kit (optional extra)

ELECTRONIC CONTROL

The CDP 45 has a built-in hygrostat and is fully automatic with electronic control. The hygrostat is factory set to approx. 60% RH. An easy to read display panel indicates the current status of operation.

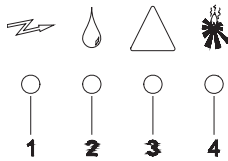

1. Power on
2. Dehumidification – the compressor is on
3. Cooling circuit failure – the dehumidifier is switched off
4. After heating coil is activated.

Passive, demand-controlled defrosting is incorporated in the electronic control. A sensor on the evaporator coil ensures that the evaporator is only defrosted when required. The compressor is switched off during defrosting and the fans blow room air through the evaporator, thereby melting the ice on the evaporator.

If the relative humidity has to be adjusted frequently, a remote room hygrostat can be connected to the CDP 45.

TECHNICAL DATA

		CDP 45
Operating range – humidity	%RH	40 – 100
Operating range – temperature	°C	10 – 36
Air volume	m ³ /h	500
Power supply	V/Hz	1x230/50
Max. ampere consumption	A	4,3
Max. power consumption	kW	1,05
Refrigerant		R407C
Quantity of refrigerant	kg	0,950
Sound level (at 1 metre)	dB(A)	49
Weight	kg	74
Colour	RAL	7044 / 9016
Protection class		IPX4

CAPACITY CURVES

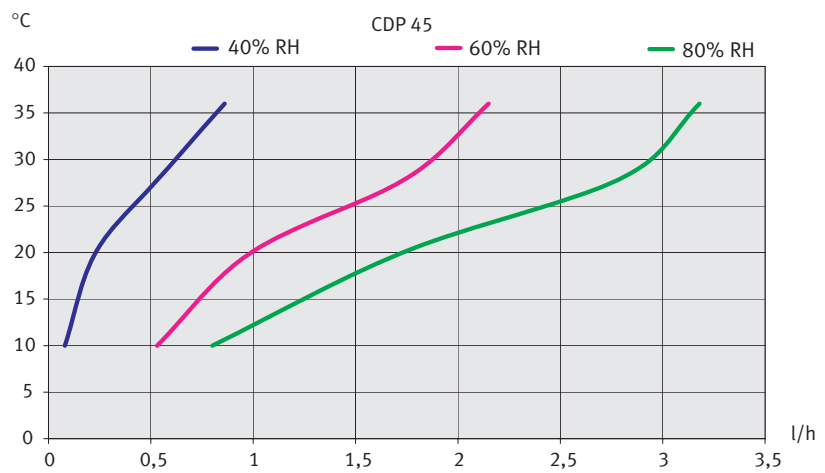

DIMENSIONS

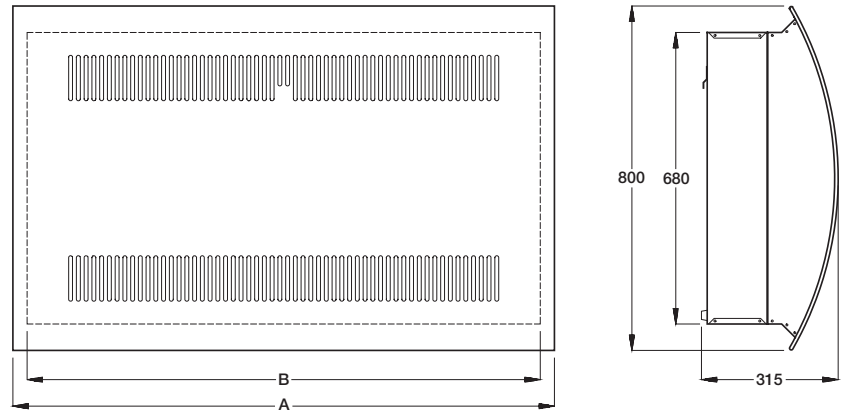

	A	B
CDP 45	1260	1200

Drain outlet position

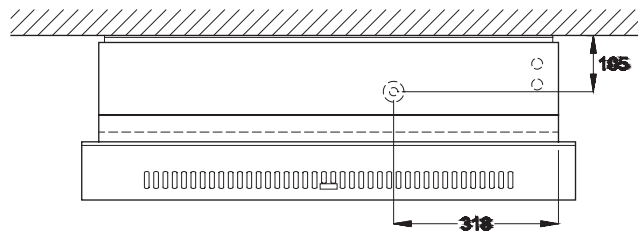

Recommended placing of the CDP 45

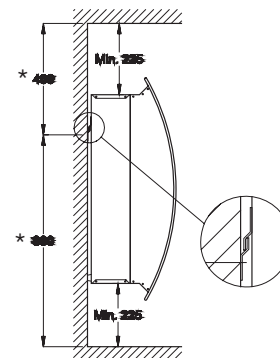

Floor mounting kit

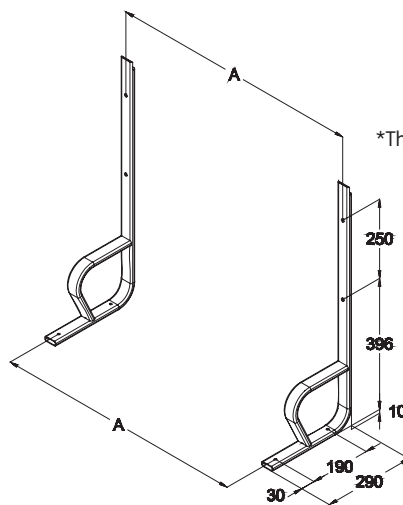

*The dimensions indicate the placing of the wall mounting strip

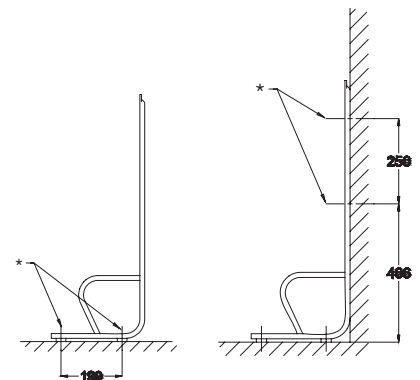

* To be fixed to the floor or the wall

	A
CDP 45	950

ACCESSORIES

- Room hygrosat
- Floor mounting kit
- Ext. failure monitoring
- After heating coil

All dimensions are in mm

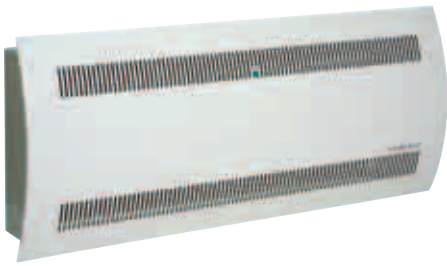

CDP 65

FUNCTION

The CDP 65 works in accordance with the condensation principle. Three fans draw the humid air into the dehumidifier and through an evaporator coil. When passing through the evaporator the air is cooled down to below its dew point temperature, and its content of water vapour is condensed into water, which falls into the drip tray and then is led from the drip tray to a drain. The cold, dry air is then passed over the condenser coil where it is re-heated, before leaving the unit at a temperature, which is approx. 5°C higher than at the inlet.

CONSTRUCTION

- The CDP 65 is built into a hot-galvanized sheet metal cabinet
- All external and internal parts of the cabinet are enamel powder painted
- The CDP 65 is fixed to the wall by means of a wall mounting strip supplied with the unit
- The condensate outlet is located at the bottom of the CDP 65. The outlet stub can be connected to a 1/2" water hose
- Air intake through a filter that is placed behind the front panel
- Rotary compressor
- Radial fans
- The CDP 65 can be floor mounted using a floor mounting kit (optional extra)

ELECTRONIC CONTROL

The CDP 65 has a built-in hygrostat and is fully automatic with electronic control. The hygrostat is factory set to approx. 60% RH. An easy to read display panel indicates the current status of operation.

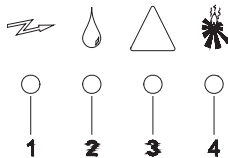

1. Power on
2. Dehumidification – the compressor is on
3. Cooling circuit failure – the dehumidifier is switched off
4. After heating coil is activated.

Passive, demand-controlled defrosting is incorporated in the electronic control. A sensor on the evaporator coil ensures that the evaporator is only defrosted when required. The compressor is switched off during defrosting and the fans blow room air through the evaporator, thereby melting the ice on the evaporator.

If the relative humidity has to be adjusted frequently, a remote room hygrostat can be connected to the CDP 65.

TECHNICAL DATA

		CDP 65
Operating range – humidity	%RH	40 – 100
Operating range – temperature	°C	10 – 36
Air volume	m ³ /h	750
Power supply	V/Hz	1x230/50
Max. ampere consumption	A	7,2
Max. power consumption	kW	1,65
Refrigerant		R407C
Quantity of refrigerant	kg	1,600
Sound level (at 1 metre)	dB(A)	51
Weight	kg	101
Colour	RAL	7044 / 9016
Protection class		IPX4

CAPACITY CURVES

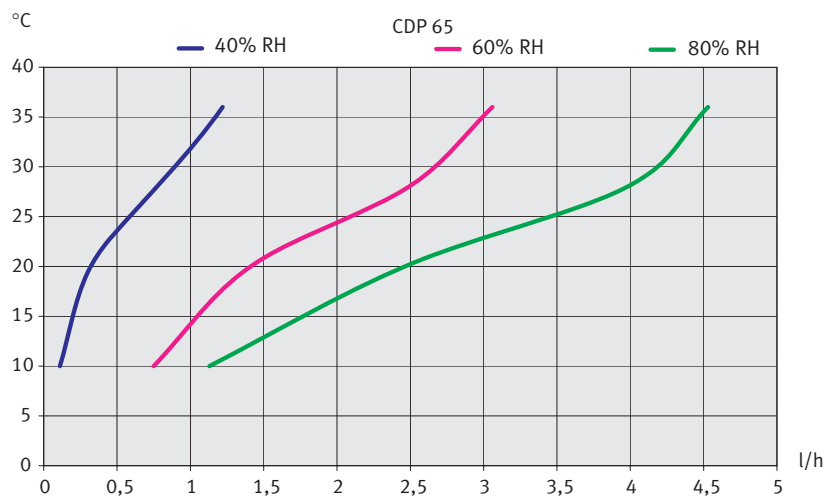

DIMENSIONS

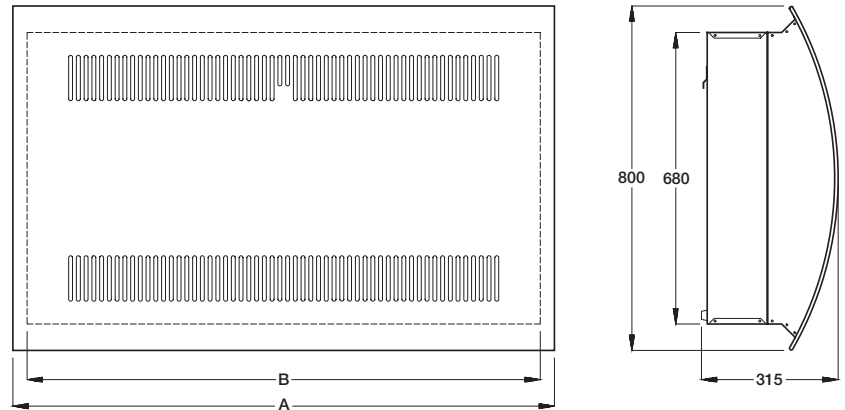

	A	B
CDP 65	1800	1735

Drain outlet position

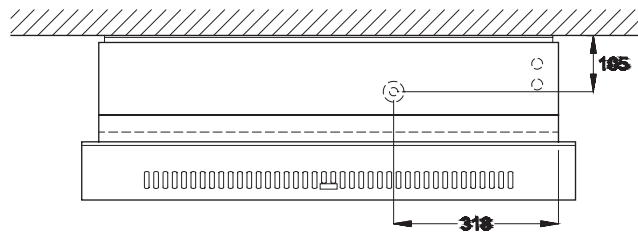

Recommended placing of the CDP 65

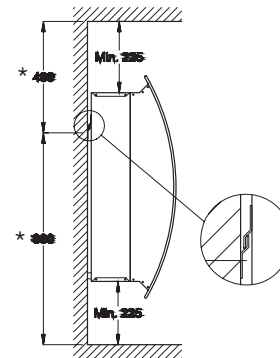

Floor mounting kit

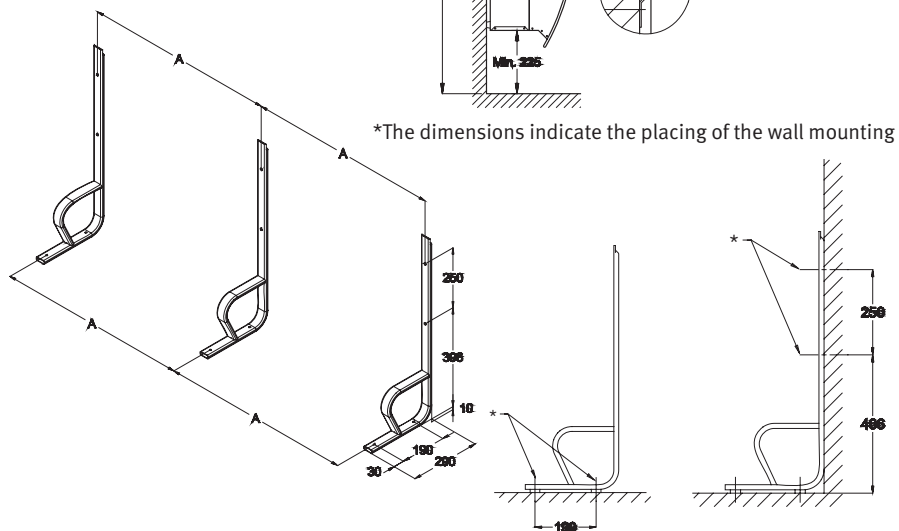

	A
CDP 65	745

* To be fixed to the floor or the wall

ACCESSORIES

- Room hygrosat
- Floor mounting kit
- Ext. failure monitoring
- After heating coil

All dimensions are in mm

