

CDP 75



FUNCTION

The CDP 75 works in accordance with the condensation principle. A fan draws the humid air into the dehumidifier and through an evaporator coil. When passing through the evaporator the air is cooled down to below its dew point temperature, and its content of water vapour is condensed into water, which falls into the drip tray and then is led from the drip tray to a drain. The cold, dry air is then passed over the condenser coil where it is re-heated, before leaving the unit at a temperature, which is approx. 5°C higher than at the inlet.

CONSTRUCTION

- The CDP 75 is built into a cabinet made of hot-galvanized double-skinned panels with 50 mm insulation
- All external and internal parts of the cabinet are enamel powder painted
- The condensate outlet is located on the air inlet side of the CDP 75. The outlet stub can be connected to a 3/4" water hose.
- Ø400mm air inlet through a filter placed in a removable frame
- Ø400mm dry air outlet positioned either horizontally, or vertically through the top of the unit
- The access for inspection can be moved to the opposite side
- Fresh air inlet possible through Ø160mm fresh air duct
- The CDP 75 can be supplied with an optional water-cooled condenser. The Ø15mm coupling pipes of the water-cooled condenser are made of copper
- Rotary compressor
- Radial fan
- The CDP 75 can be wall mounted utilising the wall mount kit or it can be placed on the floor utilising the shockabsorbing floor mount kit (optional extra)
- A water heating coil can be mounted in the air outlet duct for further heating of the dry air (optional extra)

Capacity of water-cooled condenser

		CDP 75
Connection	mm	Ø15
Max. water flow	l/h	600
Max. capacity*	kW	4,0
Pressure drop	kPa	10

* Running conditions: LP 10°C, HP 40°C, water temperature 28°C

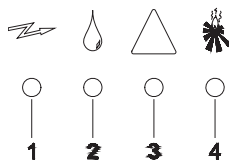

ELECTRONIC CONTROL

The CDP 75 is fully automatic with electronic control. An easy to read display panel indicates the current status of operation.

1. Power on
2. Dehumidification – the compressor is on
3. Cooling circuit failure – the dehumidifier is switched off
4. Water heating coil is activated

Push buttons allow switching on and off control of dehumidification, re-heating coil and continuous ventilation.

If a controlled and constant relative humidity is required, room or duct hygrometers can be connected to the CDP 75. If the CDP 75 is used with a water-heating coil, the control is prepared for connection of a room thermostat.

If the CDP 75 is used in the temperature range between 15 and 20°C, passive, demand-controlled defrosting can be achieved by fitting a defrosting sensor on the evaporator coil.

TECHNICAL DATA

		CDP 75
Operating range – humidity	%RH	40 – 100
Operating range – temperature	°C	20 – 38
Air volume	m ³ /h	1500
Max. external pressure	Pa	140
Max. fresh air supply	m ³ /h	225
Power supply	V/Hz	1x230/50
Max. ampere consumption	A	9,5
Max. power consumption	kW	1,85
Refrigerant		R407C
Quantity of refrigerant	kg	2,100
Sound level (at 1 metre)	dB(A)	58
Weight	kg	130
Filter		EU 3
Colour	RAL	9016
Protection class		IPX4

CAPACITY CURVES

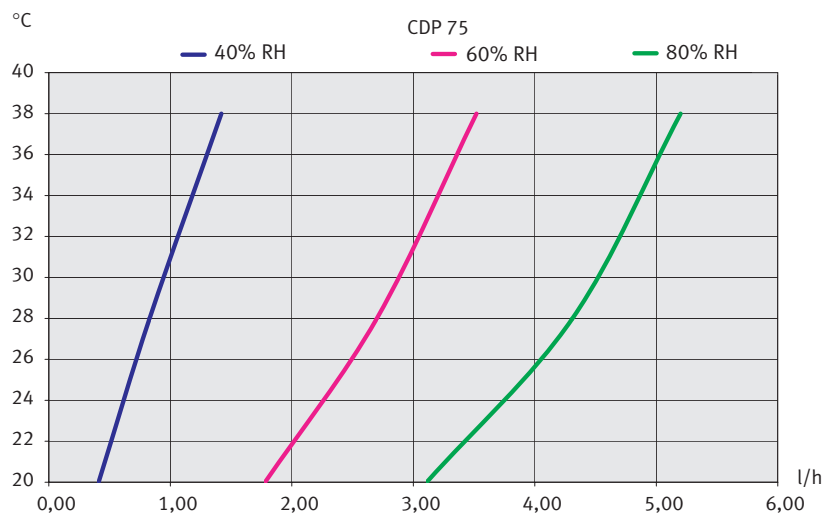

DIMENSIONS

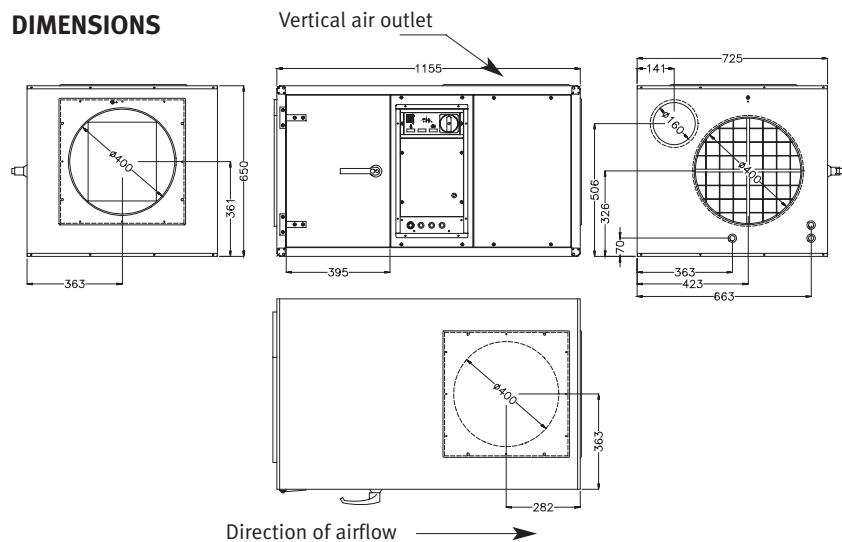

ACCESSORIES

- Wall mount kit
- Shockabsorbing floor mount kit
- Water heating coil
- Room hygostat
- Duct hygostat
- Room thermostat
- Defrost sensor
- Ext. failure monitoring

Wall mount kit

	A	B	C	D
CDP 75	365	270	1092	932

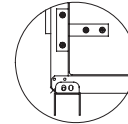
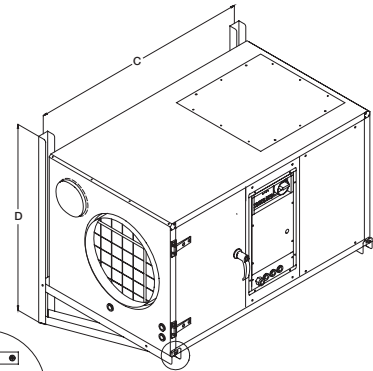
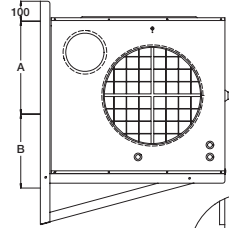

The bracket is fastened by a screw in the popnut

Shockabsorbing floor mount kit

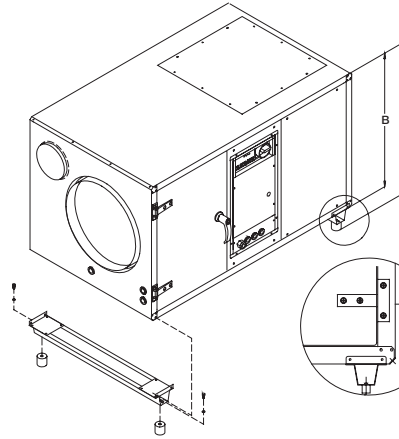

	A	B
CDP 75	745±2	650

The floor mount kit is fastened by a M5 sheet metal screw

Water heating coil

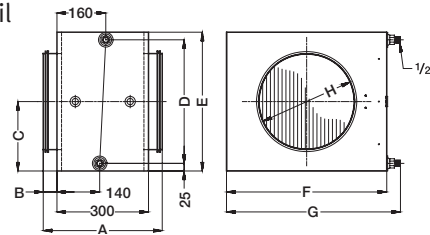

	A	B	C	D	E	F	G	H	Kg
Ø400	410	55	240	430	580	650	695	400	28

Capacity of water heating coil

CDP 75		2RR	2RR	2RR
Connection		1/2"	1/2"	1/2"
Duct connection	mm	Ø400	Ø400	Ø400
Water temperature	°C	82/71	80/60	70/35
Air volume	m ³ /h	1500	1500	1500
Air outlet temperature	°C	56,78	51,67	36,56
Capacity	kW	15,15	12,54	4,86
Water flow	l/h	1152	504	108
Pressure drop, water	kPa	5,68	1,40	0,09
Pressure drop, air	Pa	11,10	11,01	10,75

The technical specifications of the water heating coils are based on a room temperature of 27°C

All dimensions are in mm



CDP 125

FUNCTION

The CDP 125 works in accordance with the condensation principle. A fan draws the humid air into the dehumidifier and through an evaporator coil. When passing through the evaporator the air is cooled down to below its dew point temperature, and its content of water vapour is condensed into water, which falls into the drip tray and then is led from the drip tray to a drain. The cold, dry air is then passed over the condenser coil where it is re-heated, before leaving the unit at a temperature, which is approx. 5°C than at the inlet.

CONSTRUCTION

- The CDP 125 is built into a cabinet made of hot-galvanized double-skinned panels with 50 mm insulation
- All external and internal parts of the cabinet are enamel powder painted
- The condensate outlet is located on the air inlet side of the CDP 125. The outlet stub can be connected to a 3/4" water hose
- Ø400mm air inlet through a filter placed in a removable frame
- Ø400mm dry air outlet positioned either horizontally, or vertically through the top of the unit
- The access for inspection can be moved to the opposite side
- Fresh air inlet possible through Ø160mm fresh air duct
- The CDP 125 can be supplied with an optional water-cooled condenser. The Ø15mm coupling pipes of the water-cooled condenser are made of copper
- Reciprocating compressor
- Radial fan
- The CDP 125 can be wall mounted utilising the wall mount kit or it can be placed on the floor utilising the shockabsorbing floor mount kit (optional extra)
- A water heating coil can be mounted in the air outlet duct for further heating of the dry air (optional extra)

Capacity of water-cooled condenser

		CDP 125
Connection	mm	Ø15
Max. water flow	l/h	700
Max. capacity*	kW	4,5
Pressure drop	kPa	13

* Running conditions: LP 10°C, HP 40°C, water temperature 28°C

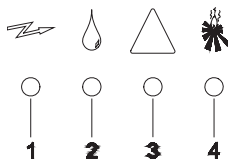

ELECTRONIC CONTROL

The CDP 125 is fully automatic with electronic control. An easy to read display panel indicates the current status of operation.

1. Power on
2. Dehumidification – the compressor is on
3. Cooling circuit failure – the dehumidifier is switched off
4. Water heating coil is activated

Push buttons allow switching on and off control of dehumidification, re-heating coil and continuous ventilation.

If a controlled and constant relative humidity is required, room or duct hygrometers can be connected to the CDP 125. If the CDP 125 is used with a water-heating coil, the control is prepared for connection of a room thermostat.

If the CDP 125 is used in the temperature range between 15 and 20°C, passive, demand-controlled defrosting can be achieved by fitting a defrosting sensor on the evaporator coil.

ACCESSORIES

- Wall mount kit
- Shockabsorbing floor mount kit
- Water heating coil
- Room hygostat
- Duct hygostat
- Room thermostat
- Defrost sensor
- Ext. failure monitoring

Wall mount kit

	A	B	C	D
CDP 125	465	370	1237	1180

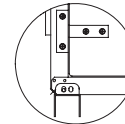
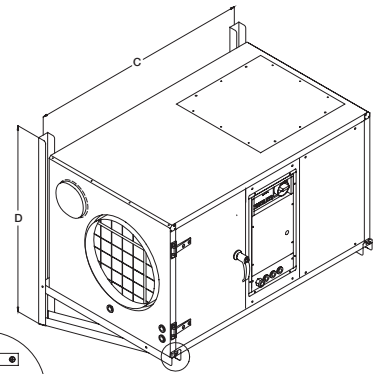
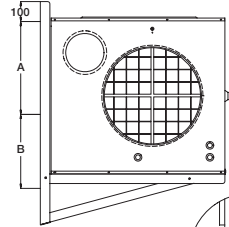

The bracket is fastened by a screw in the popnut

Shockabsorbing floor mount kit

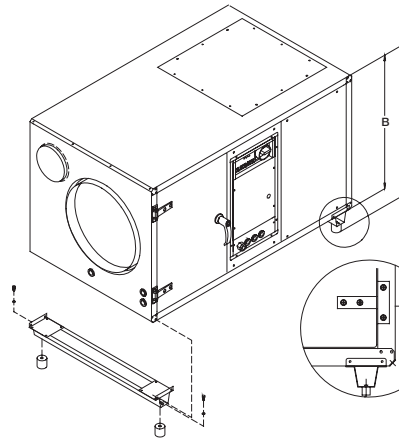

	A	B
CDP 125	942±2	850

The floor mount kit is fastened by a M5 sheet metal screw

Water heating coil

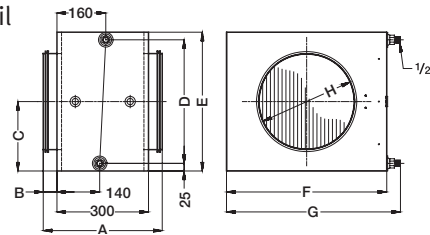

	A	B	C	D	E	F	G	H	Kg
Ø400	410	55	240	430	580	650	695	400	28

Capacity of water heating coils

CDP 125		2RR	2RR	2RR
Connection		1/2"	1/2"	1/2"
Duct connection	mm	Ø400	Ø400	Ø400
Water temperature	°C	82/71	80/60	70/35
Air volume	m ³ /h	2500	2500	2500
Air outlet temperature	°C	51,58	47,11	34,42
Capacity	kW	20,84	17,05	6,29
Water flow	l/h	1620	720	144
Pressure drop, water	kPa	10,09	2,44	0,15
Pressure drop, air	Pa	28,63	28,42	27,84

All dimensions are in mm

The technical specifications of the water heating coils are based on a room temperature of 27°C



CDP 165

FUNCTION

The CDP 165 works in accordance with the condensation principle. A fan draws the humid air into the dehumidifier and through an evaporator coil. When passing through the evaporator the air is cooled down to below its dew point temperature, and its content of water vapour is condensed into water, which falls into the drip tray and then is led from the drip tray to a drain. The cold, dry air is then passed over the condenser coil where it is re-heated, before leaving the unit at a temperature, which is approx. 5°C higher than at the inlet.

CONSTRUCTION

- The CDP 165 is built into a cabinet made of hot-galvanized double-skinned panels with 50 mm insulation
- All external and internal parts of the cabinet are enamel powder painted
- The condensate outlet is located on the air inlet side of the CDP 165. The outlet stub can be connected to a 3/4" water hose.
- Ø500mm air inlet through a filter placed in a removable frame
- Ø500mm dry air outlet positioned either horizontally, or vertically through the top of the unit
- The access for inspection can be moved to the opposite side
- Fresh air inlet possible through Ø160mm fresh air duct
- The CDP 165 can be supplied with an optional water-cooled condenser. The Ø15mm coupling pipes of the water-cooled condenser are made of copper
- Reciprocating compressor
- Radial fan
- The CDP 165 can be placed on the floor utilising the shockabsorbing floor mount kit (optional extra)
- A water heating coil can be mounted in the air outlet duct for further heating of the dry air (optional extra)

Capacity of water-cooled condenser

		CDP 165
Connection	mm	Ø15
Max. water flow	l/h	800
Max. capacity*	kW	5,5
Pressure drop	kPa	16

* Running conditions: LP 10°C, HP 40°C, water temperature 28°C

ELECTRONIC CONTROL

The CDP 165 is fully automatic with electronic control. An easy to read display panel shows the current status of operation.

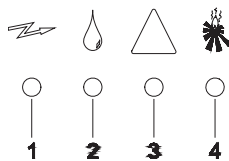

1. Power on
2. Dehumidification – the compressor is on
3. Cooling circuit failure – the dehumidifier is switched off
4. Water heating coil is activated

Push buttons allow switching on and off control of dehumidification, re-heating coil and continuous ventilation.

If a controlled and constant relative humidity is required, room or duct hygrometers can be connected to the CDP 165. If the CDP 165 is used with a water-heating coil, the control is prepared for connection of a room thermostat.

If the CDP 165 is used in the temperature range between 15 and 20°C, passive, demand-controlled defrosting can be achieved by fitting a defrosting sensor on the evaporator coil.

TECHNICAL DATA

		CDP 165
Operating range – humidity	%RH	40 – 100
Operating range – temperature	°C	20 – 38
Air volume	m ³ /h	3600
Max. external pressure	Pa	240
Max. fresh air supply	m ³ /h	540
Power supply	V/Hz	3x230/50 / 3x400/50
Max. ampere consumption	A	20,2 / 11,5
Max. power consumption	kW	4,3
Refrigerant		R407C
Quantity of refrigerant	kg	6,800
Sound level (at 1 metre)	dB(A)	63
Weight	kg	190
Filter		EU 3
Colour	RAL	9016
Protection class		IPX4

CAPACITY CURVES

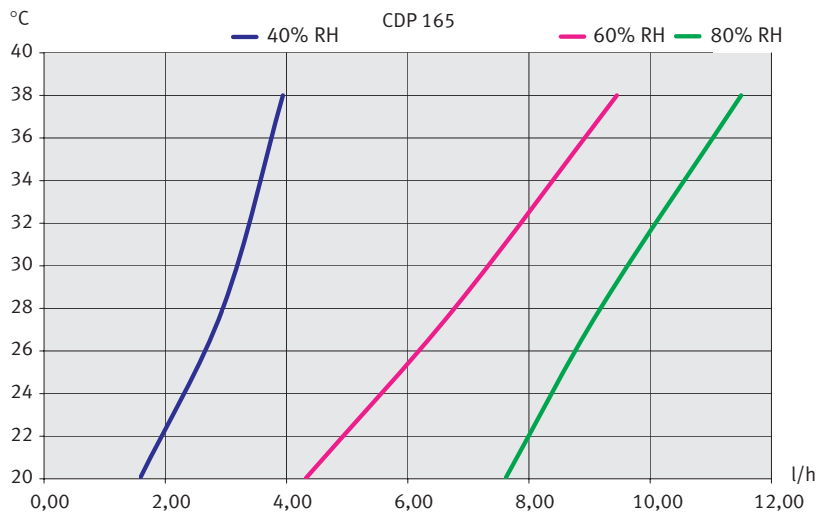

DIMENSIONS

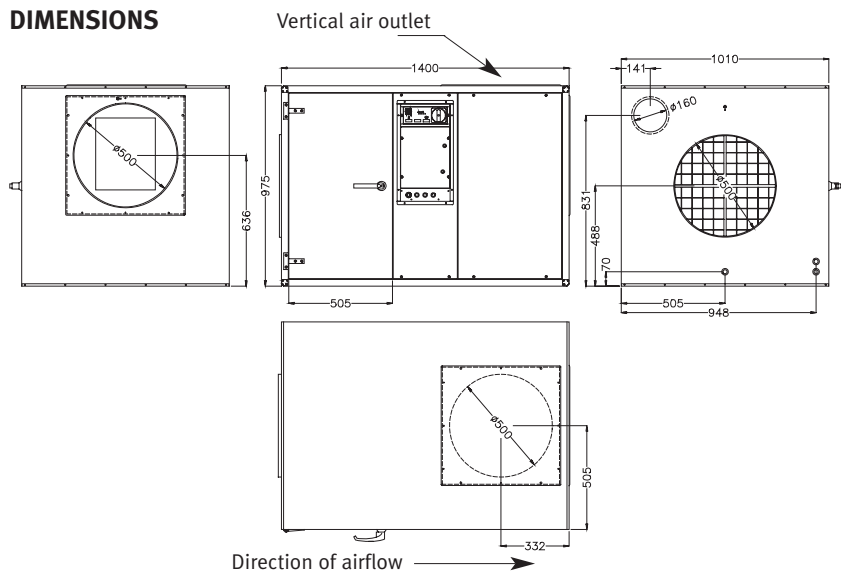

ACCESSORIES

- Shockabsorbing floor mount kit
- Water heating coil
- Room hygrostat
- Duct hygrostat
- Room thermostat
- Defrost sensor
- Ext. failure monitoring

Shockabsorbing floor mount kit

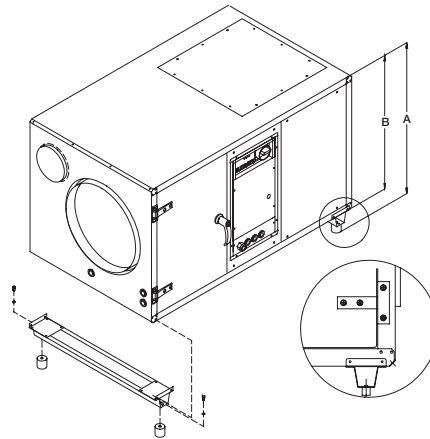

	A	B
CDP 165	1067±2	975

The floor mount kit is fastened by a M5 sheet metal screw

Water heating coil

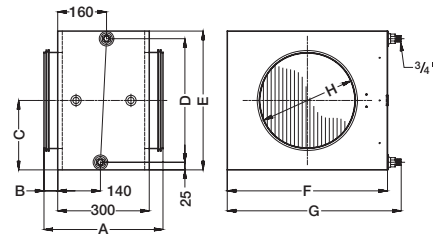

	A	B	C	D	E	F	G	H	Kg
Ø500	410	55	352	655	705	775	820	500	34

Capacity of water heating coils

CDP 165		2RR	2RR	2RR
Connection		3/4"	3/4"	3/4"
Duct connection	mm	Ø500	Ø500	Ø500
Water temperature	°C	82/71	80/60	70/35
Air volume	m ³ /h	3600	3600	3600
Air outlet temperature	°C	52,29	47,86	35,09
Capacity	kW	30,87	25,47	9,87
Water flow	l/h	2376	1080	216
Pressure drop, water	kPa	13,17	3,24	0,22
Pressure drop, air	Pa	25,92	25,74	25,21

The technical specifications of the water heating coils are based on a room temperature of 27°C

All dimensions are in mm

Large swimming pools and similar applications

For dehumidification of swimming pools and other fields of use that are beyond the capacities mentioned in this catalogue - please consult Dantherm's ventilation catalogue in which you will find detailed information of heat pumps especially for swimming pool dehumidification.



